

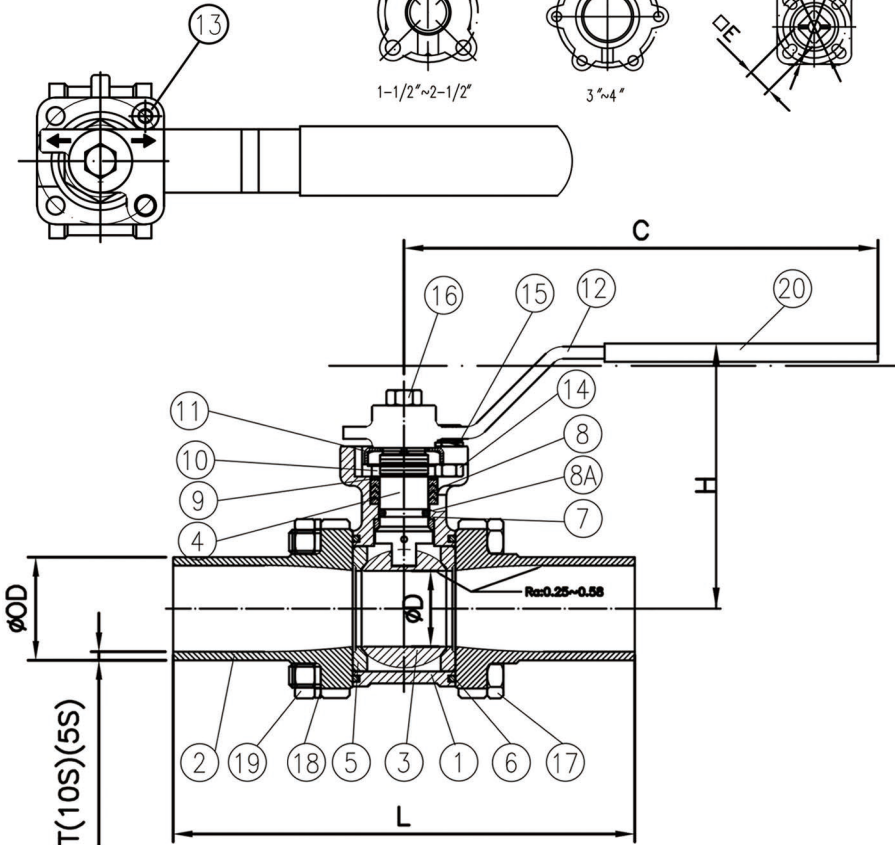

- MODEL NO: GKV-32B (TUBE · SCH5 · SCH10)
- . BLOW-OUT PROOF STEM
- . BUILT-IN ISO5211 MOUNTING PAD FOR EASY AUTOMATION MEDIA THRU THE VALVE
- . FULL PORT FOR TUBING BUTT-WELD
- . BOSSES FOR TUBING BUFF-WELD
- . BOSSES FOR PURGE CONNECTIONS ARE BUILT INTO BODY AND CAP FOR SIP/CIP OPERATIONS.
- . ALL WETTED PARTS ARE POLISHED TO 180 GRIT RMS 0.5 TO 0.64 MICRON
- . SWING-OUT 3PC DESIGN FOR EASY FIELD MAINTENANCE.
- . ALL EXTENDED WELD IN SS316L MATERIAL ALLOWS ORBITAL WELDING IN PLACE.
- . HIGH PURITY CLEANING OIL FREE AND PACKING.
- . VITON O-RING ON STEM GIVES EXTRA SUPPORT AND ASSURANCE OF TIGHTNESS.

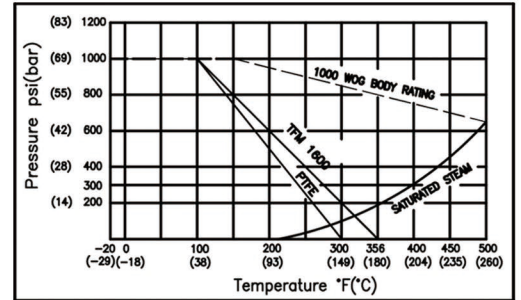
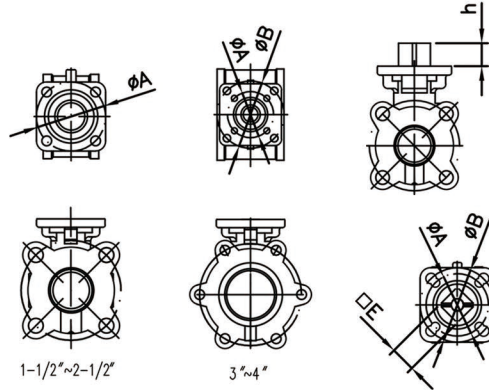

EXTEND BUTT-WELD FOR 5S(10S)

ITEM	名稱	材質	數量
1	Body	CF8M	1
2	End Cap	CF3M/CF8M	2
3	Ball	CF8M	1
4	Anti Static Stem	SS316	1
5	Ball Seat	TFM1600/PTFE	2
6	Body Seal	PTFE,TEFLON	2
7	Thrust Washer	PTFE,TEFLON	1
8A	O-Ring	VITON	1
8	Stem Packing	PTFE,TEFLON	1
9	Thrust Washer	50%SS,50%PTFE	1
10	Stem Nut	SS304	1
11	Lock Saddle	SS304	1
12	Handle	SS304	1
13	Stop Bolt	SS304	1
14	Stop Nut	SS304	1
15	Stop Washer	SS304	1
16	Handle Bolt	SS304	1
17	Body Bolt	SS304	4
18	Bolt Washer	SS304	4
19	Bolt Nut	SS304	4
20	Handle Sleeve	VINYL	1

SIZE	ϕD	ϕOD	T(SCH5)	T(SCH10)	L	C	$\square E$	ϕA	ϕB	h	H
1/2'	15	21.7	1.65	2.1	135.4	126	9	F03	F04	8	75
3/4'	20	27.2	1.65	2.1	135	126	9	F03	F04	8	78
1'	25	34.0	1.65	2.8	152	156	11	F04		10	87
1-1/4'	32	42.7	1.65	2.8	177.2	156	11	F04		10	93
1-1/2'	38	48.6	1.65	2.8	190	181	14	F05		13	114
2'	50	60.5	1.65	2.8	204	181	14	F05	F07	13	122
2-1/2'	63.5	76.3	2.1	3.0	254	300	17	F07		16	139
3'	76	89.1	2.1	3.0	280	400	17	F07	F10	16	149
4'	97	114.3	2.1	3.0	306	500	22	F07	F10	21	178